



Set using ISO screws

TA-1130

General Export Model

GEP Model

NEP Model

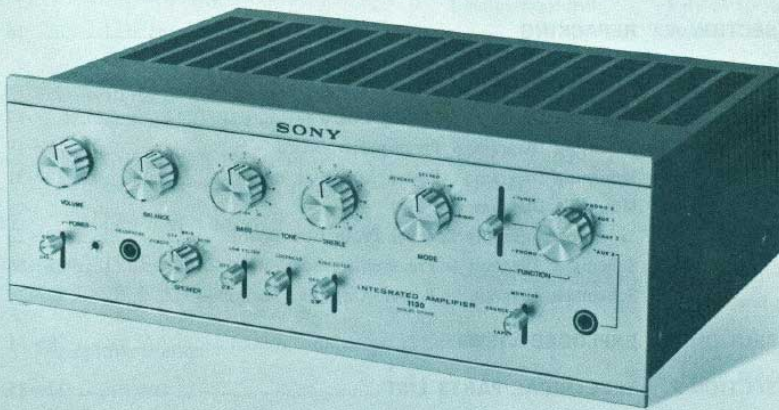

SONY[®]
SERVICE MANUAL

TABLE OF CONTENTS

	<u>Title</u>	<u>Page</u>
SECTION 1. TECHNICAL DESCRIPTION		
1-1.	Technical Specification	1
1-2.	Detailed Circuit Analysis	2~7
1-3.	Level Diagram	7
1-4.	Block Diagram	8
SECTION 2. DISASSEMBLY AND REPLACEMENT PROCEDURES		
2-1.	Tools Required	9
2-2.	Hardware Identification Guide	9
2-3.	Top Cover and Front Panel Removal	9
2-4.	Front Subchassis Removal	10
2-5.	Control and Switch Replacement	11
2-6.	Rear Panel Removal	11
2-7.	Power Transistor Replacement	12
2-8.	Replacement of Components Secured to the Rear Panel by Rivets	12
2-9.	Chassis Layout	13
SECTION 3. ADJUSTMENTS		
3-1.	Power Supply Voltage Adjustment for Preamplifier Section	14
3-2.	Power Amplifier Adjustments	14~15
SECTION 4. REPACKING		
		16
SECTION 5. DIAGRAMS		
5-1.	Mounting Diagram - Muting Board -	17
5-2.	Mounting Diagram - Preamplifier Board -	18~19
5-3.	Mounting Diagram - Power Amplifier Board -	20~21
5-4.	Mounting Diagram - Power Supply/Speaker Protection Board -	22~23
5-5.	Schematic Diagram - Preamplifier Section -	25~26
5-6.	Schematic Diagram - Power Amplifier Section -	27~28
SECTION 6. EXPLODED VIEWS		
		29~31
SECTION 7. ELECTRICAL PARTS LIST		
		32~35

SECTION 1

TECHNICAL DESCRIPTION

1-1. TECHNICAL SPECIFICATIONS

Technical specifications for the TA-1130 are given in Table 1-1.

TABLE 1-1. SPECIFICATIONS

Power Amplifier Section			
Dynamic power output:	230 watts (4 ohms), both channels operating	Signal output and impedance:	TAPE : 130 mV, 100 k REC/PB : 130 mV, 100 k AUX 1,2,3 : 130 mV, 100 k REC OUT : 150 mV, 10 k REC/PB out : 30 mV, 82 k PRE OUT : 1 V, 5 k
(IHF constant power supply method)	200 watts (8 ohms), both channels operating	Signal-to-noise ratio:	PHONO 1, 2 : greater than 70 dB (weighting network A)
Continuous RMS power:	70 watts (4 ohms) per channel, both channels operating 65 watts (8 ohms) per channel, both channel operating	Tone controls:	TAPE: } greater than REC/PB: } 90 dB (weighting network A) AUX 1,2,3: }
20 Hz to 20 kHz power output:	50 watts (8 ohms) both channels operating	Filters:	BASS : ±10 dB at 100 Hz (10 steps by 2 dB each) TREBLE : ±10 dB at 10 kHz (10 steps by 2 dB each)
Power bandwidth:	7 Hz to 30 kHz, IHF	Loudness control:	+8 dB at 50 Hz, +3 dB at 10 kHz (with 30 dB attenuation)
Harmonic distortion: (20 Hz ~ 20 kHz)	Less than 0.1% at 1 kHz at rated output Less than 0.05% at 1 watt output	Harmonic distortion:	Less than 0.1% at 1 kHz at rated output
IM distortion: (60 Hz: 7 kHz = 4 : 1)	Less than 0.1% at rated output Less than 0.05% at 1 watt output	IM distortion: (60 Hz : 7 kHz = 4 : 1)	Less than 0.1% at rated output
Frequency response:	10 Hz to 200 kHz (±0 dB) at 1 watt output		
Signal-to-noise ratio:	Greater than 110 dB (shorted input, weighting network A)		
Residual noise:	Less than 0.008μW		
Input sensitivity and impedance:	1V for rated output, 90 k ohms (POWER AMP INPUT)		
Preamplifier Section		General	
Frequency response:	PHONO 1, 2 : RIAA curve ±0.5 dB TAPE : 10Hz to 100kHz REC/PB : 10Hz to 100kHz AUX1,2,3 : 10Hz to 100kHz TUNER : 10Hz to 100kHz	Power consumption:	Approx. 280 watts (GEP and General Export Model) Approx. 210 watts (NEP Model)
Input sensitivity and impedance:	PHONO 1, 2 : 1.2 mV, 47 k TUNER : 130 mV, 100 k	Power requirement:	100, 117, 220 or 240 volts, 50/60 Hz ac
		Dimensions:	400 mm (width) × 149 mm (height) × 327 mm (depth) 15 ³ / ₄ "(width) × 5 ⁷ / ₈ "(height) × 12 ⁷ / ₈ "(depth)
		Net weight:	13 kg (28 lb 11 oz)
		Shipping weight:	14.9 kg (32 lb 14 oz)

1-2. DETAILED CIRCUIT ANALYSIS

The following describes the function or operation of all stages and controls. The text sequence follows signal paths. Stages are listed by transistor reference designation at the left margin; major components are also listed in a similar manner. Refer to the block diagram on page 8 and the schematic diagram on pages 25 to 28.

Stage/Control

Function

Preamplifier Section

Equalizer amplifier
Q101, Q102

This direct-coupled two-stage amplifier (FET-NPN) amplifies the small signal provided by the phono cartridge to the level required at the input of the following tone-control amplifier. An FET has an high input impedance and generates less noise than conventional silicon transistors.

Therefore, FETs are employed in the preamplifier stages.

The FETs used in the preamplifier stages are selected according to their I_{dss} rank, and care should be taken to use replacement FETs with the exact same I_{dss} rank.

I_{dss} rank is indicated by the identification number, as illustrated in Fig. 1-1.

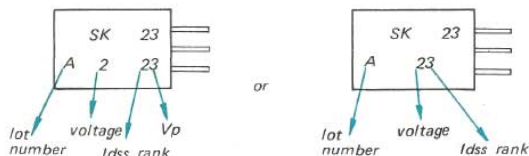

Fig. 1-1 Example of I_{dss} rank

Stage/Control

Function

Bias circuit
R110, R109
R102

Dc bias voltage for Q101 is extracted from R110 in the emitter circuit of Q102 and fed back to the gate of Q101 through R109 and R102. This dc negative feedback technique provides stable operation.

Equalization circuit
R111, R112,
R113, R104
C107, C108,
C109

RIAA equalization is achieved by the negative-feedback loop containing R111, R112, R113, R104, C107, C108 and C109.

Be sure to use replacement components with the exact same values.

R115 (215) in the output circuit prevents interaction between left and right channel equalization when the MODE switch is set to L+R.

MONITOR switch
S3

Selects the signals from TAPE, AUX or equalizer outputs.

MODE switch
S4

Selects the desired mode of operation. This switch may also be used for test purposes. The relation between the positions of the MODE switch and outputs of the set are summarized in the table below.

VOLUME control
RV302

The equalized phono signals and signals applied to the other input terminals are fed to the VOLUME control through the MONITOR and MODE switches. The level of the signal applied to the following tone-control amplifier is determined by the setting of RV302.

TABLE 1-2.

OUTPUTS MODE SELECTOR SWITCH POSITION	SPEAKER	SPEAKER	HEAD- PHONE	HEAD- PHONE	REC	REC	PRE- AMP	PRE- AMP
	OUT; LEFT	OUT; RIGHT	OUT; LEFT	OUT; RIGHT	OUT; LEFT	OUT; RIGHT	OUT; LEFT	OUT; RIGHT
REVERSE	R	L	R	L	L	R	R	L
STEREO	L	R	L	R	L	R	L	R
L + R	L + R	L + R	L + R	L + R	L + R	L + R	L + R	L + R
LEFT	L	L	L	L	L	L	L	R
RIGHT	R	R	R	R	R	R	L	R

Stage/Control	Function	Stage/Control	Function
LOUDNESS switch S5	This switch and R301, R302, C301 and C302 compensate for the characteristics of the human ear which vary according to the loudness of the sound being heard. When this switch is set to ON, and the VOLUME control is set for 30 dB attenuation, the overall frequency response is increased 8 dB at 50 Hz and 3 dB at 10 kHz with reference to the level at 1 kHz.	LOW FILTER switch S9	high-frequency components (6 dB/oct above 7 kHz) from the input signal when this switch is ON. Cuts out unwanted low frequency components from the input signal (6 dB/oct below 100 Hz) in the ON position.
Tone-control amplifier Q301, Q302, Q303	This three-stage amplifier has basically flat response, but it operates as a negative-feedback type tone-control circuit. The input signals are amplified by Q301 and Q302, and then applied to Q303 (source follower). The output generated at the source circuit of Q303 is fed back to the source circuit of Q301 through the treble and bass tone-control network.	Muting circuit for preamplifier Q921, Q922 (Q923) R994, C991	This muting circuit prevents the loud "pop" (due to initial current flow) or click noises produced by switch controls just after turning the power switch to ON. These transients might damage a delicate high-fidelity speaker system. The base of Q922 (Q923) is connected to the collector circuit of Q921 through R998 (R999), while the base of Q921 is connected to an RC network (R994, C991) with a long time constant. When you first turn ON the power switch, Q921 remains off due to the long time constant of the associated bias circuit, while Q922 (Q923) is forward biased by R996. As a result, Q922 (Q923) is ON, shorting the preamplifier's output to ground. Thus the preamplifier's output is effectively muted. As Q921 is gradually turned ON due to the slowly-increasing base current flow, Q921 conducts and cuts off Q922, removing the muting.
BASS control switch S6-1F, S6-1R	Decreases the amount of negative feedback voltage by switching the resistors connected to S6-1F in steps for increasing the low-frequency components of the signal. Conventional RC filter network techniques are applied to obtain proper response at low frequencies by switching the resistors connected to S6-1R in steps.	NORMAL/SEPARATE switch S10	In NORMAL, the output of the preamplifier is fed to the power amplifier's input through S10. In SEPARATE, the output of the preamplifier is disconnected from the power amplifier's input terminal, allowing you to use the sections separately.
TREBLE control switch S7-1R, S7-1F	Decreases the amount of negative feedback voltage by switching the resistors connected to S7-1R in steps when increasing the high-frequency components. The conventional RC filter network techniques are applied to obtain proper response at high frequencies by switching the resistors connected to S7-1F in steps. This has a range of ± 10 dB at 10 kHz.	Power Amplifier Section	
HIGH FILTER switch S8	The high-cutoff filter (R344 and C314) eliminates unwanted	Preamplifier Q701, Q702	Q701 and Q702 form a para-phase amplifier, but signal out-

Stage/Control	Function	Stage/Control	Function
	<p>put is extracted from the collector circuit of Q701. This circuit has a various advantages in direct coupling systems. One is high stability despite temperature variations and another is high input impedance without reducing the amplifier's gain.</p>		<p>followers. The ac load resistor for this stage is R714.</p>
	<p>The ac output appears across load resistor R712 (R812) in the collector circuit. An emitter decoupling circuit is formed by the emitter-base resistance of Q702, C702 and R710 in the base circuit of Q702.</p>	<p>Dc bias adj. (idling current) Q705, R715</p>	<p>Q705 is biased into conduction and operates as a small resistance providing the necessary forward bias on the two cascaded emitter-followers. R715 controls the base bias of Q705, determining its emitter-collector impedance and thereby controls the dc bias voltage for the following complementary circuit.</p>
	<p>An emitter circuit formed by the emitter-base resistance of Q702, C702 and R710 is essentially a frequency-selective ac bypass to reduce the amplifier's gain at very low frequencies.</p>	<p>Thermal compensator for dc bias D702 (D802)</p>	<p>The negative temperature coefficient of diodes D702 and (D802) provides thermal compensation for the complementary and power-transistor circuits. D702 is attached to the power transistor's heat sink to detect temperature increases in the power transistors.</p>
	<p>Common emitter-resistor R711 keeps the dc current flow constant in Q701 and Q702, thus increasing the dc stability.</p>	<p>Complementary circuit Q710, Q711</p>	<p>These transistors operate as emitter-followers to provide the current swings demanded of the output stages and also provide the necessary phase inversion. Phase inversion is performed by using PNP and NPN type transistors.</p>
<p>Dc balance adj. R702</p>	<p>The stabilized positive and negative power supply voltages are picked off by R908 and R907, R909 and R908, and applied to R702 or R802, R702 provides a stabilized bias voltage for transistor Q701 to set the output terminal voltage at zero dc.</p>	<p>Power transistors Q712, Q713</p>	<p>The output transistors Q712 and Q713 are connected directly to a power supply of about ± 50 V. Q712 supplies power to the load during the positive half cycle and Q713 operates during the negative half cycle. As all the stages are directly coupled and designed to obtain zero potential at the output terminal, the large coupling capacitor at the output which may cause power loss or distortion at low frequencies is eliminated.</p>
<p>Thermal compensation and noise suppressor D701</p>	<p>As all the stages are directly coupled, dc stability is required. The negative temperature coefficient of D701 provides thermal compensation for the following driver stage. It also acts as a noise suppressor to reduce the popping noise caused by unbalanced current flow in the following stages when the power switch is turned off.</p>	<p>Protection circuit</p>	<p>Two kinds of protection circuits are employed in this power amplifier. One is a power-transistor protection circuit and the</p>
<p>Driver Q704</p>	<p>Though this stage is a conventional flat amplifier, it determines the output voltage swings because the following stages are basically emitter-</p>		

Stage/Control

Function

other is a speaker-system protection circuit.

Power-transistor protection circuit

To protect overloaded power transistors from destruction, a new protection circuit is employed.

In the event of a short circuit at the output terminals, the protection circuit holds down the current in the power transistor and also limits the input drive signals.

Fig. 1-2 shows a partial schematic diagram detailing this protection circuit. With reference to this diagram, the protection circuit operates as follows:

(Since the protection circuit is identical for positive-going half cycles and negative-going half cycles, only the positive-going half cycle operation is described here.)

Q707 limits the positive-going half cycle of the drive voltage applied to the base of Q710 when power consumption at the Q712 collector exceeds the safety margin.

Since power dissipation at the collector can be considered a function of collector voltage and

Stage/Control

Function

current, the trigger signal for Q707 is taken from the collector and emitter.

Base voltage is partly determined by the ratio of resistor R720 to the series resistance consisting of R724, R728, R736 and RL (load).

Base voltage is also determined by the current flow in R736 and the collector voltage of Q712.

During normal operation, Q707 is cut off. When excessive current flows in the power transistor or power dissipation at the collector of the power transistor exceeds the specified value, Q707 turns ON and limits the input drive voltage to the power transistor.

Limiting operation is also actuated by the condition of the load.

The base voltage of Q707 is determined by resistances R726, R722, R728, R736 and RL (load). D706 prevents reverse voltage from being applied during the negative going half cycle.

Q707 turns ON limiting the input drive voltage to the power transistor when the load resistance decreases to some extent.

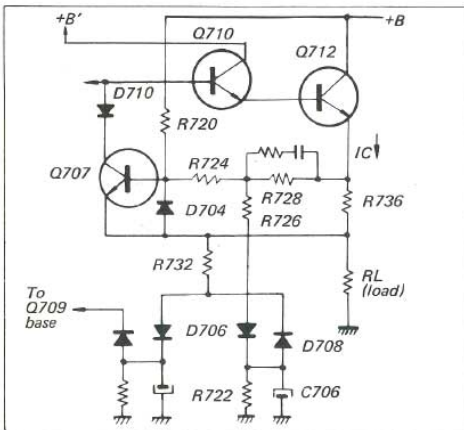

Fig. 1-2 Simplified protection circuit

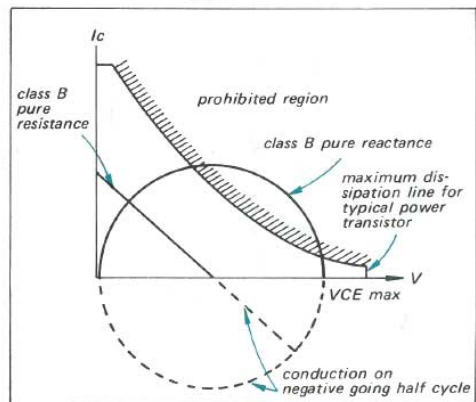

Fig. 1-3 Resistive and reactive load lines for class B output stage showing breakdown risk

Stage/Control

Function

Under reactive load conditions in class B amplifiers, maximum current will flow when the voltage across the power transistor is maximum. This is the worst case for secondary breakdown. See Fig. 1-3.

Since all speakers have reactive properties, the protection circuit must take care of this problem. Fig. 1-3 shows the operating load lines for one half of a class B output stage under conditions of equal load impedance; in one case the load is purely reactive, a load case which would result in transistor failure.

Through a complex network of resistors and transistors, D708, C706 and R732 change the base voltage of Q707 according to the reactive voltage induced in the load to provide proper protection.

Diode D706 detects reactive voltage at the output terminal and charges C706. This voltage changes the bias on Q707 to compensate for the reactive voltage.

D704 protects Q707 from breakdown between base and emitter due to detected reactive voltage across C706.

Stage/Control

Function

Speaker protection circuit

In a direct-coupled power amplifier, some faults in the early-stage transistors appears as a large unbalanced dc voltage across output terminal. This might damage a delicate speaker system.

Therefore, the TA-1130 incorporates a speaker protection circuit which operates as follows (refer to Fig. 1-4):

The output signal is extracted from the output terminal through a low-pass filter (R931 or R932, C931 and C932) and fed to the bridge rectifier (D906 ~ D909).

Because of this filter, the voltage applied to the bridge rectifier is only the very-low frequency or dc component caused by transistor faults. When the rectified dc voltage becomes large enough, it starts the Hartley oscillator (Q905 and T osc).

The oscillator's output is rectified by D910 and thus provides trigger voltage for SCR D911. When the trigger voltage is applied to the gate of the SCR, the SCR turns on and shorts the base voltage of Q710 to ground through D912, the SCR, and D915. The base voltage of Q711 is also shorted to ground through D914, the SCR, and D913. This stops any current flow in the output stage and thus protects the speaker system.

Note that the direction of diodes D912, SCR D911 and D913 also ensure speaker protection even if one of the power transistors is damaged by accident, by forcing the other power transistor into secondary breakdown.

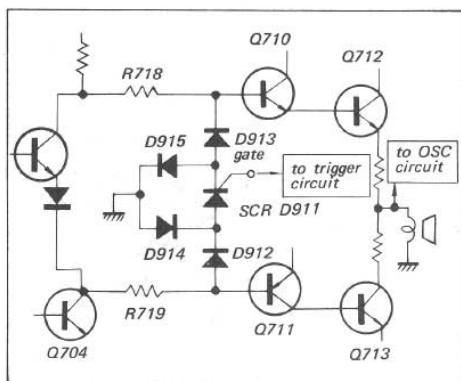

Fig. 1-4 Speaker protection circuit

Stage/Control

Function

Stage/Control

Function

Power-Supply Section

Rectifier D903 A full-wave bridge rectifier and center-tapped transformer provides positive and negative dc power supplies for the power amplifier.

Rectifier D904, D905 A pair of half-wave rectifiers (D904 and D905) and filter capacitors (C916 and C924) supply additional dc voltage in series with the bridge-rectifier output for the complementary stages.

Ripple filter Q903, R912, R913, C914, Q904, R915, R916, C922 These components reduce the ripple voltages in the dc power supply for preamplifier and driver stages of the power amplifier section to an extremely-low value.

Q903 and Q904 serve as an electronic filter to supply well-filtered dc of about $\pm 53V$ to preamplifier stages in the power amplifier.

Regulated power supply Q906, Q907, Q908

Dc output from rectifier D918 is filtered by C944 and applied to series regulator Q906. Transistor Q908 compares a sample of the output voltage picked off across R956 with reference voltage supplied by voltage stabilizer D917.

A change in output voltage is detected at the base of Q908 and therefore alters collector voltage.

Since the collector of Q908 is directly coupled to the base of Q907, the change in output voltage alters the conduction of Q907 and Q906 by the amount necessary to maintain the output voltage constant. An increase in output voltage causes an increase in the impedance (decrease in conduction) of Q906, and vice versa.

The dc output voltage supplied to the preamplifier section is therefore, extremely stable.

1-3. LEVEL DIAGRAM

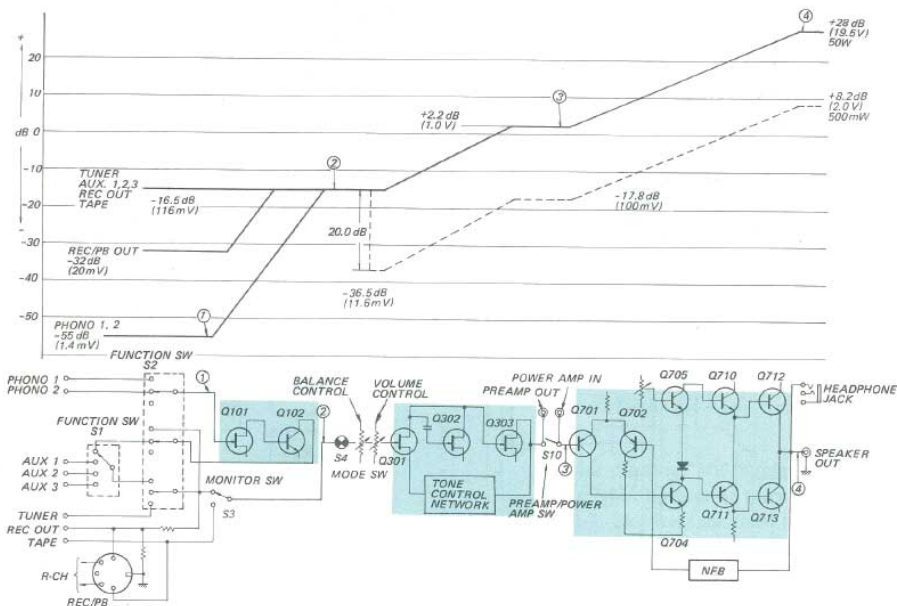

SECTION 2

DISASSEMBLY AND REPLACEMENT PROCEDURES

WARNING

Unplug the ac power cord before starting any disassembly or replacement procedures.

2-1. TOOLS REQUIRED

The following tools are required to perform disassembly and replacement procedures on the TA-1130.

1. Screwdriver, Phillips-head
2. Screwdriver, 3 mm ($\frac{1}{8}$ ") blade
3. Pliers, long-nose
4. Diagonal cutters
5. Wrench, adjustable
6. Tweezers
7. Electric drill
8. Drill bits
9. Prick punch
10. Hammer, ball-peen
11. Soldering iron, 40 to 50 watts
12. Solder, rosin core
13. Cement solvent
14. Cement, contact
15. Silicone grease

2-2. HARDWARE IDENTIFICATION GUIDE

The following chart will help you to decipher the hardware codes given in this service manual.

Note: All screws in the TA-1130 are manufactured to the specifications of the International Organization for Standardization (ISO). This means that the new and old screws are not interchangeable because ISO screws have a different number of threads per mm compared to the old ones. The ISO screws have an identification mark on their heads as shown in Fig. 2-1.

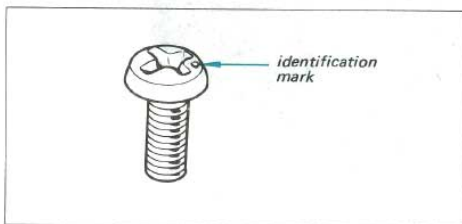

Fig. 2-1 ISO screw

Hardware Nomenclature

P	— Pan Head Screw	
PS	— Pan Head Screw with Spring Washer	
K	— Flat Countersunk Head Screw	
B	— Binding Head Screw	
RK	— Oval Countersunk Head Screw	
T	— Truss Head Screw	
R	— Round Head Screw	
F	— Flat Fillister Head Screw	
SC	— Set Screw	
E	— Retaining Ring (E Washer)	
	W — Washer	
	SW — Spring Washer	
	LW — Lock Washer	
	N — Nut	

— Example —

2-3. TOP COVER AND FRONT PANEL REMOVAL

1. Remove the two machine screws at each side of the case, and lift off the top cover.
2. Remove all control knobs and levers.
The knobs can be removed by loosening the slotted set screws and pulling the knobs straight out.
The levers are simply pulled off.
3. Remove the three screws (+PSW 4x6) behind the top edge of the front subchassis as shown in Fig. 2-2.
4. Remove the three self-tapping screws (+B 3x6) at the front bottom of the chassis as shown in Fig. 2-3. This frees the front panel.

2-4. FRONT SUBCHASSIS REMOVAL

The front subchassis is the vertical member on which all the controls, switches, and pilot lamp are attached.

- 1. Remove the top cover and front panel as described in Procedure 2-3.
- 2. Remove the two screws (@ B 3x6) at each side of the chassis (see Fig. 2-5) and four self-tapping screws (@ B 3x6) at the front bottom of the chassis as shown in Fig. 2-3. This frees front subchassis as shown in Fig. 2-4.

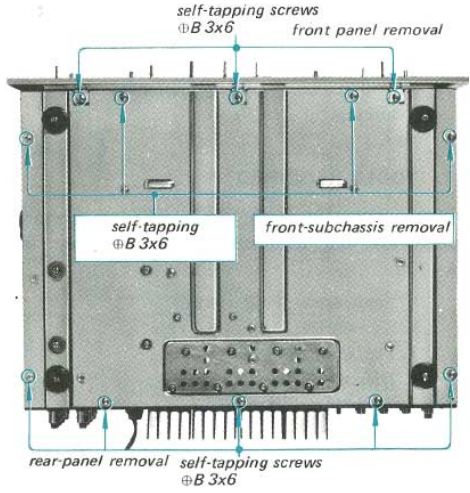

Fig. 2-3 Bottom view

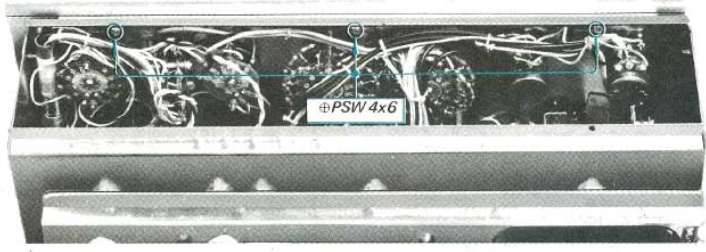

Fig. 2-2 Front-panel removal

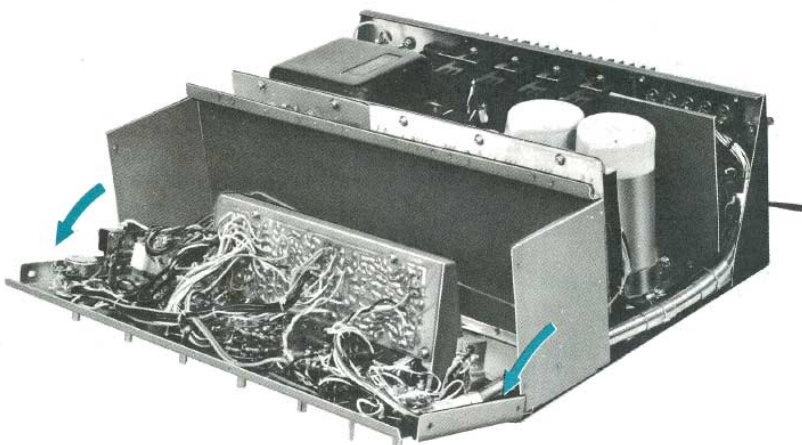

Fig. 2-4 Front subchassis removal

2.5. CONTROL AND SWITCH REPLACEMENT

Prepare for replacing any of the controls or switches by removing the front subchassis as described in Procedure 2-4.

POWER, LOW FILTER, HIGH FILTER, LOUDNESS, MONITOR and FUNCTION (2) Switches

1. Remove the two screws (\oplus PS 3x5) securing switches to the front subchassis as shown in Fig. 2-5.
2. Unsolder the lead wires from the defective switch, and then install the replacement switch.

SPEAKER, MODE, FUNCTION (1) Switches and VOLUME, BALANCE, BASS and TREBLE Controls

1. Remove the hex nuts that secure the switches or controls to the front subchassis as shown in Fig. 2-5.
2. Unsolder the lead wires from the defective switch or control, and then install the new one.

HEADPHONE, AUX-3 Jacks

1. Remove the two screws (\oplus B 3x6) securing the jack escutcheon to the front subchassis.
2. Unsolder the lead wires from the defective jack, and then install the new one.

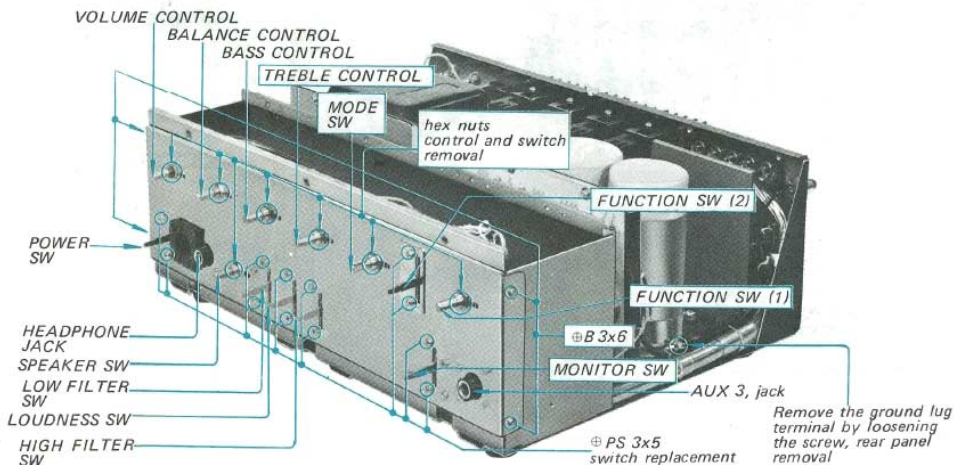

Fig. 2-5 Control and switch replacement

2-6. REAR PANEL REMOVAL

1. Remove the top cover as described in Procedure 2-3.
2. Remove the four screws (\oplus B 3x6) at each side of the chassis (see Fig. 2-6) and five self-tapping screws (\oplus B 3x6) at the rear bottom of the chassis as shown in Fig. 2-3.
3. Remove the power amplifier board, and then unsolder the lead wires coming from the NORMAL/SEPARATE switch.
4. Remove the ground lug terminal by loosening the screw securing the electrolytic capacitor (C923) bracket to the chassis as shown in Fig. 2-5.
5. Unhook the flexible conduit from the clamp located inside the rear panel, and then cut the strings tying the lead wires to the rear jacks together. This frees the rear panel.

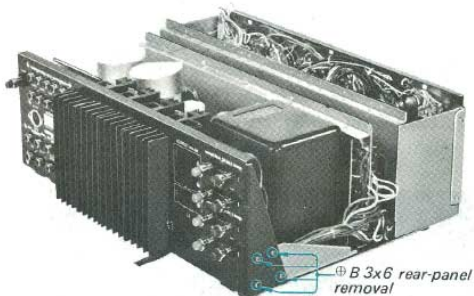

Fig. 2-6 Rear panel removal

2-7. POWER TRANSISTOR REPLACEMENT

1. Remove the top cover as described in Procedure 2-3.
2. Remove the four self-tapping screws ($\text{Ø} B 3 \times 8$) securing the top heat-sink bracket as shown in Fig. 2-7.
3. Remove the four self-tapping screws ($\text{Ø} B 3 \times 8$) securing the pair of heat sinks to the chassis as shown in Fig. 2-8.
4. Carefully draw back the pair of heat sinks, and then remove the two screws ($\text{Ø} B 3 \times 14$) and nuts securing the power transistor to the heat sink. See Fig. 2-9.
5. Cut the emitter and base leads of the defective power transistor with a diagonal cutter. This prevents mica washer damage when removing the defective power transistor.
6. When replacing the power transistor, apply a coating of a heat-transferring grease to both sides of the insulating mica washer. Any excess grease squeezed out when the mounting bolts are tightened should be wiped off with a clean cloth. This prevents it from accumulating conductive dust particles that might eventually cause a short.

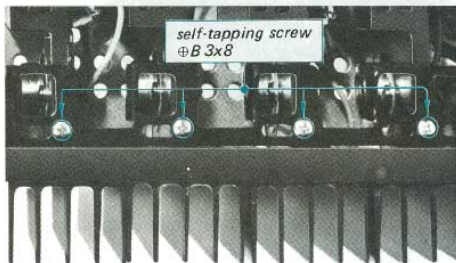

Fig. 2-7 Top heat sink removal

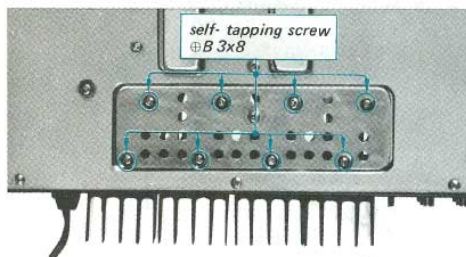

Fig. 2-8 Heat sink removal

2-8. REPLACEMENT OF COMPONENTS SECURED TO THE REAR PANEL BY RIVETS

1. Remove the rear panel as described in Procedure 2-6.
2. Bore out the rivets using a drill bit slightly larger in diameter than the rivet. See Fig. 2-10.
3. Punch out the remainder of the rivet with a nail set or prick punch.
4. Remove the defective component, and then install a new one.
5. Secure the new component with a suitable screw and nut, or a repair rivet screw (part number 3-701-402).

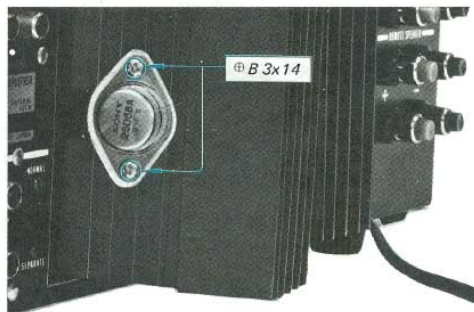

Fig. 2-9 Power transistor removal

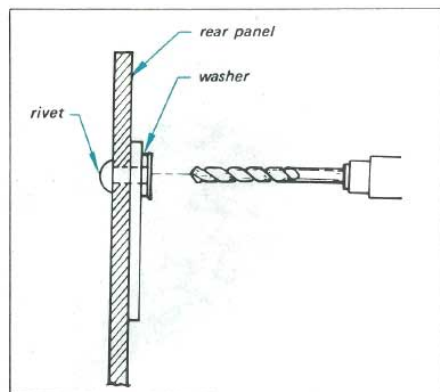
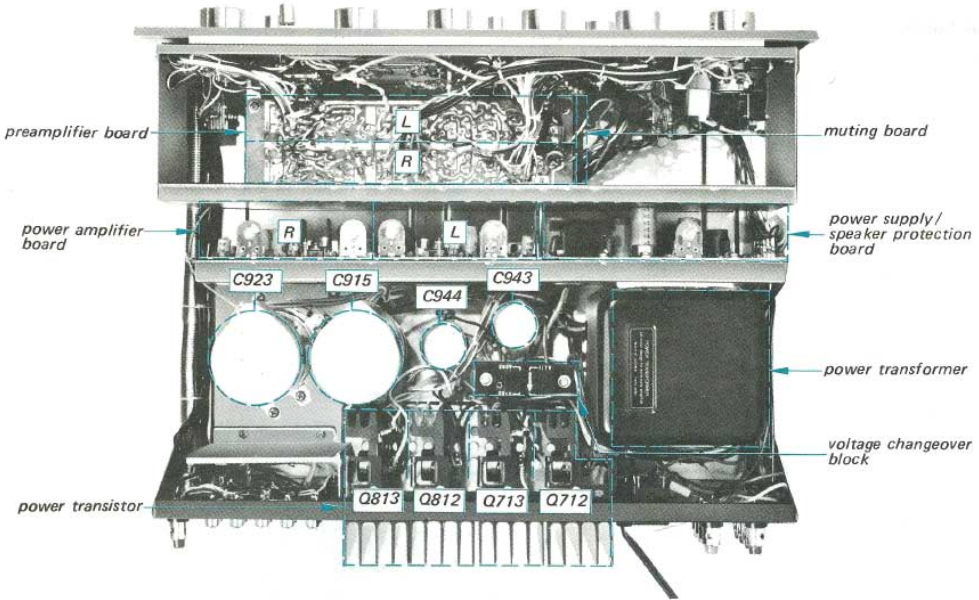

Fig. 2-10 Rivet removal

2-9. CHASSIS LAYOUT

General Export Model



GEP and NEP Model

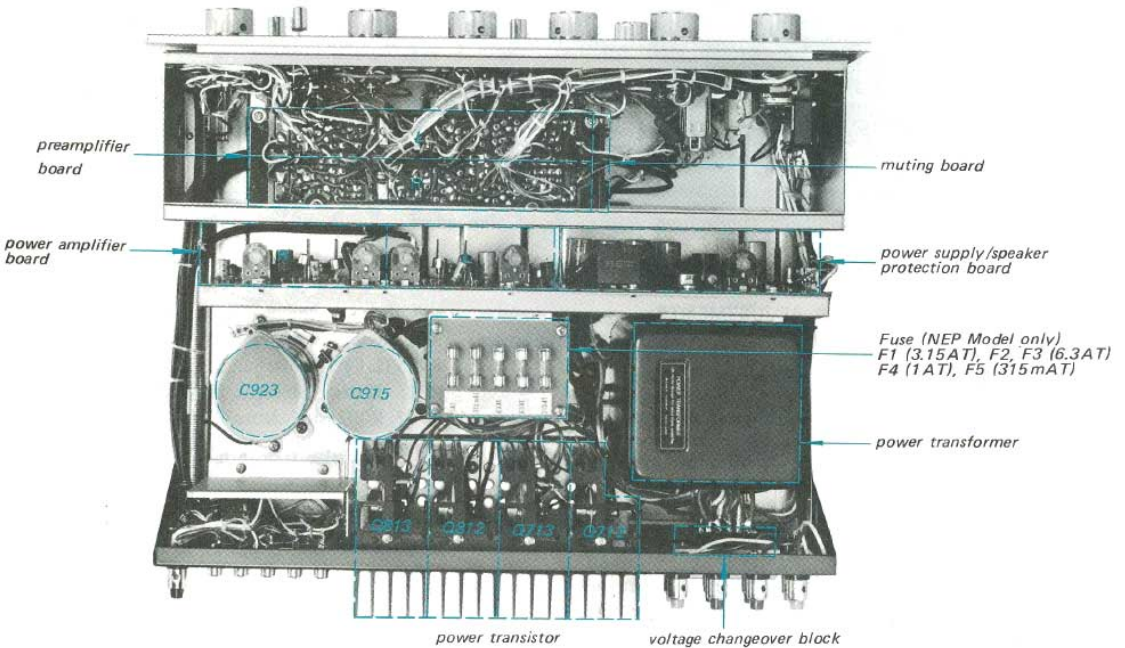

SECTION 3 ADJUSTMENTS

3-1. POWER SUPPLY VOLTAGE ADJUSTMENT FOR PREAMPLIFIER SECTION

Test Equipment Required

1. Dc voltmeter:
Capable of measuring 40V dc or more.
2. Screwdriver with 3 mm ($1/8$ ") blade
3. Variable transformer

Preparation

1. Remove the top cover as described in Procedure 2-3.
Connect the dc voltmeter to the test point as shown in Fig. 3-1.

Procedure

1. Set the variable transformer for minimum output.
2. Turn the POWER switch to ON, and then increase the line voltage up to the rated value.
3. Adjust semifixed resistor R956 (see Fig. 3-1) to obtain a 40V reading on the meter.

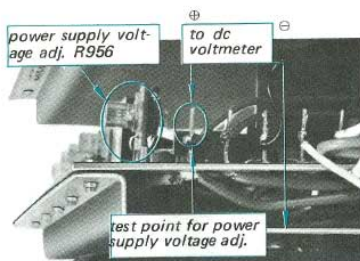

Fig. 3-1 Dc voltmeter connection and parts location

3-2. POWER AMPLIFIER ADJUSTMENTS

Note: There are two adjustments to be made in the power amplifier. One is dc-bias adjustment and the other is dc-balance adjustment. These adjustments should be alternately repeated two or three times after replacing any of the power transistors until the best operation is obtained.

Dc-bias Adjustment

Serious deficiencies in performance, such as thermal runaway of power transistors, will result if this adjustment is improperly set.

CAUTION

To avoid accidental power transistor damage, increase the ac line voltage gradually, using a variable transformer, while alternately measuring the voltage across test points and the hot side of the speaker binding post (emitter resistors R736 and R836 of the power transistors) as shown in Fig. 3-2. Check to see that the reading does not exceed 25 mV. If it does, turn off the power as soon as possible, then check and repair the trouble in the power amplifier board.

Test Equipment Required

1. Dc millivoltmeter:
Capable of measuring dc voltage of 100mV or less.
2. Variable transformer
3. Screwdriver with 3 mm ($1/8$ ") blade

Preparation

1. Remove the top cover as described in Procedure 2-3.
2. Connect the dc millivoltmeter across the test point and the hot side of the speaker binding post (L-CH) (emitter resistor R736 of power transistor Q712) as shown in Fig. 3-2.
When measuring the R-CH bias, note that the dc millivoltmeter lead should reconnect to the R-CH hot side of the speaker binding post also.

Procedure

1. Apply a drop of cement solvent to the semifixed resistors on the power amplifier board, and then set the semifixed resistors (see Fig. 3-2) on the power amplifier board as follows:
R715 (L-CH, dc-bias) fully clockwise
R815 (R-CH, dc-bias) fully counterclockwise
R702, R802 (dc-balance) mid position
2. Set the variable transformer for minimum output.
3. Turn the POWER switch to ON, and then increase the line voltage up to the rated value.
4. Adjust R715 and R815 to obtain a 25 mV reading on the meter, and then perform the dc-balance adjustment.

Dc-Balance Adjustment

Excessive harmonic distortion at high levels or speaker system damage will result if this adjustment is improperly set.

Test Equipment Required

1. Dc null meter or dc millivoltmeter.
2. Screwdriver with 3 mm (1/8") blade.

Preparation

1. Set the SPEAKER switch to MAIN.
2. Connect the dc null meter or dc millivoltmeter to the MAIN speaker output terminal.

Procedure

1. Turn the POWER switch to ON, and then adjust R702 (R802) to obtain a 0 V reading on the meter.
2. After 10 minutes warm-up, alternately repeat this and the dc-bias adjustment two or three times.
3. After completing the adjustments, apply a drop of lock paint to R715 and R702 (R815 and R802).

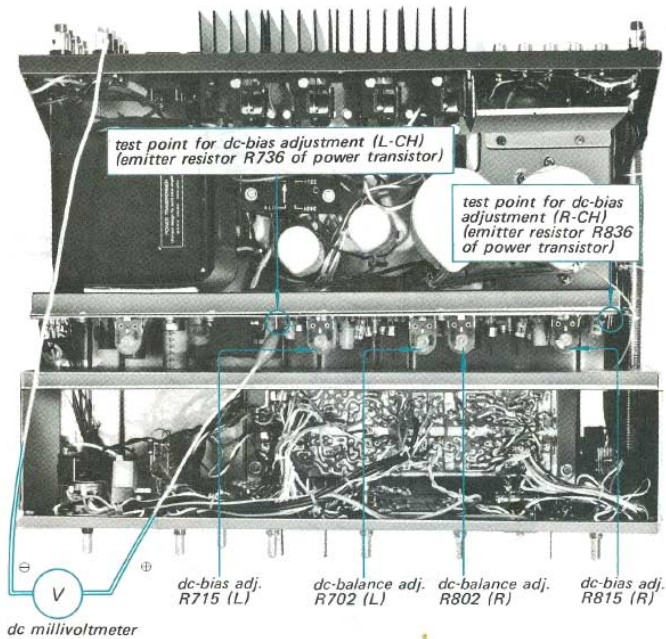

Fig. 3-2 Test points and adjustments

SECTION 4 REPACKING

The TA-1130's original shipping carton and packing materials are the ideal containers for shipping the unit. However to secure the maximum protection,

the TA-1130 must be repacked in these materials precisely as before. The proper repacking procedures are shown in Fig. 4-1.

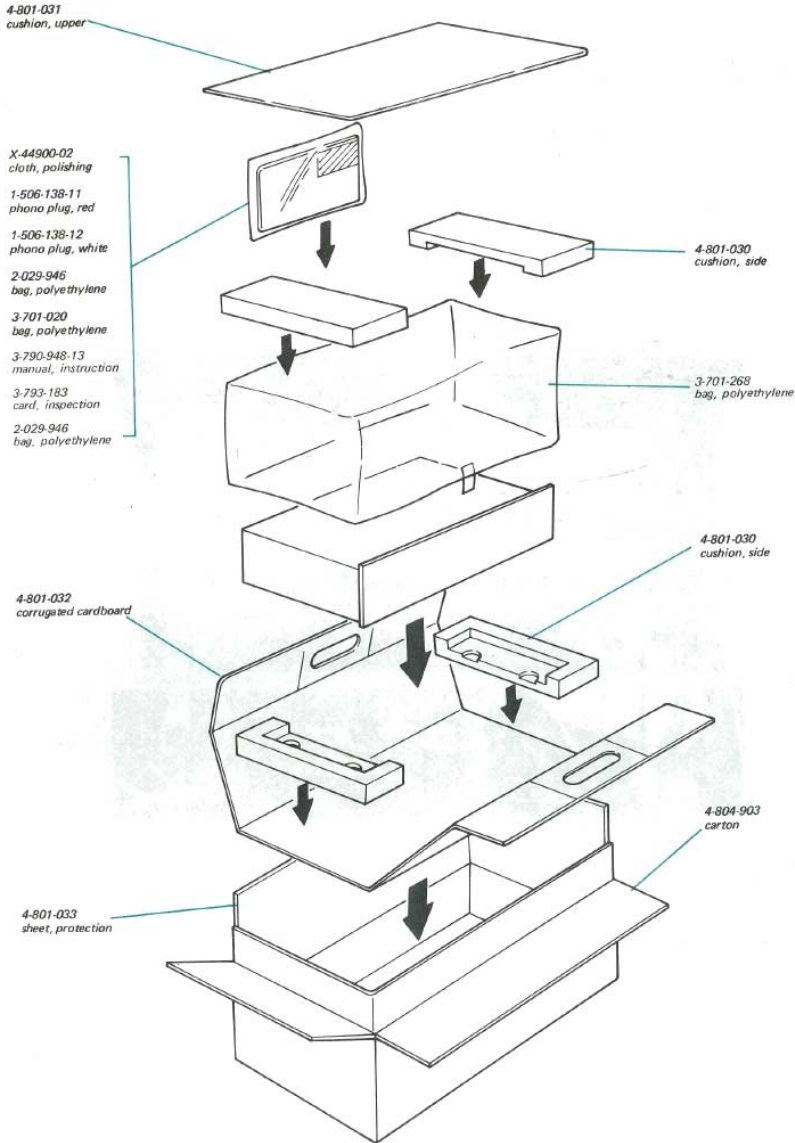
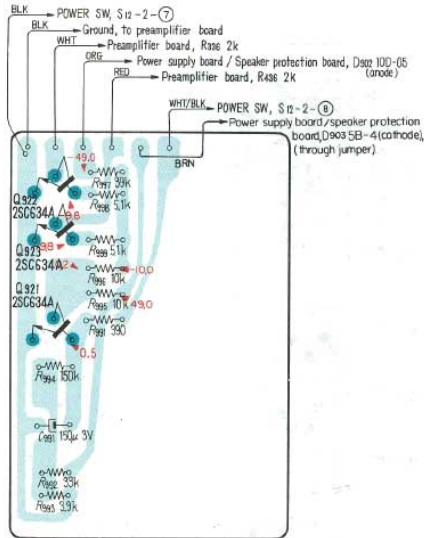

Fig. 4-1 Repacking

SECTION 5 DIAGRAMS

5-1. MOUNTING DIAGRAM – Muting Board –

– Conductor Side –



– Component Side –

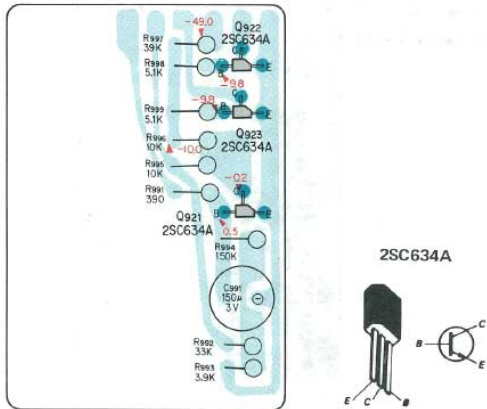

5-2. MOUNTING DIAGRAM — Preamplifier Board —

— Conductor Side —

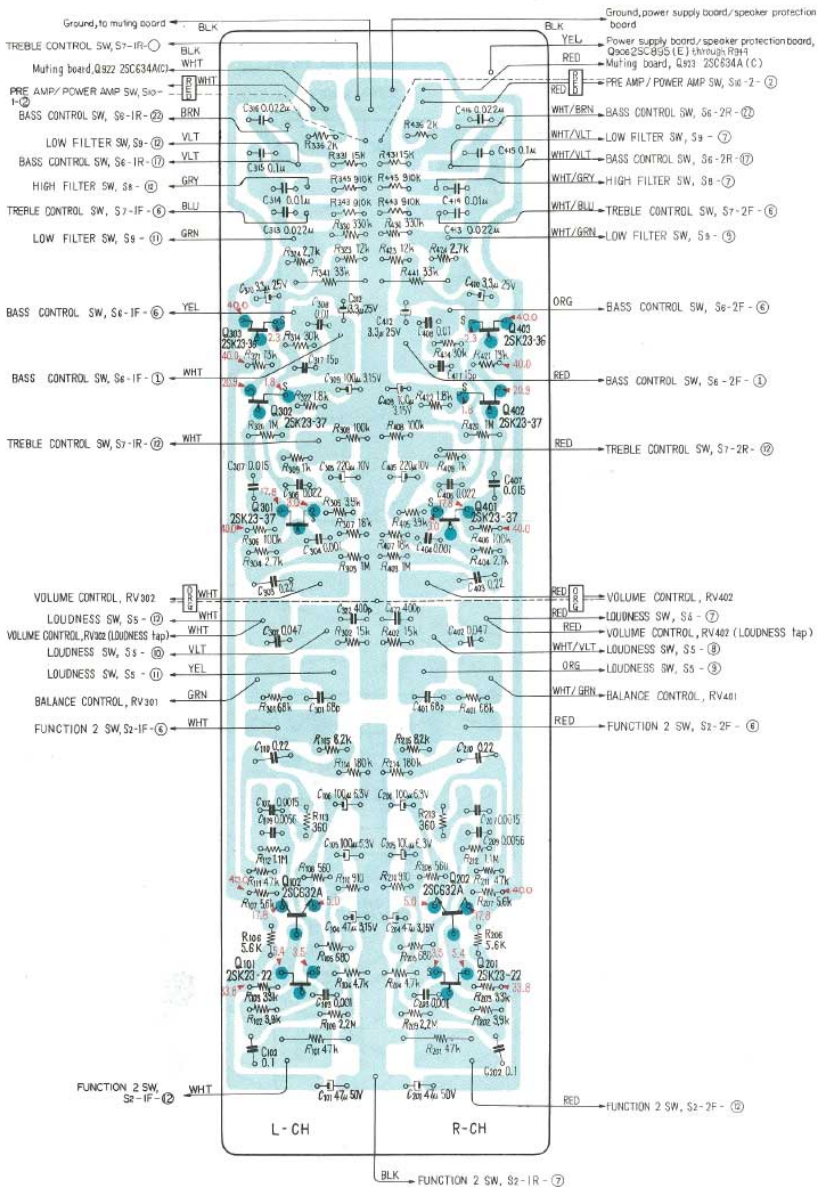

5-2. MOUNTING DIAGRAM – Preamplifier Board –

– Component Side –

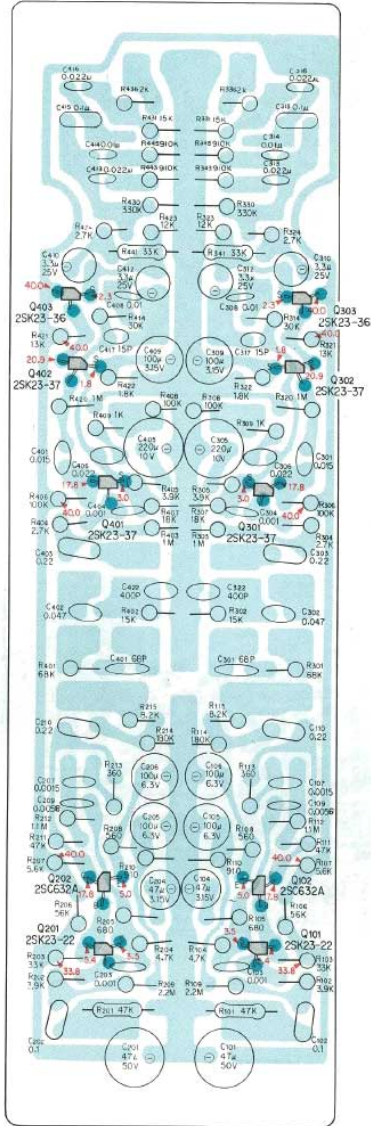

2SK23



2SC632A

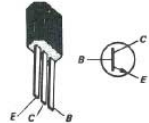

5-3. MOUNTING DIAGRAM — Power Amplifier Board —
— Conductor Side —

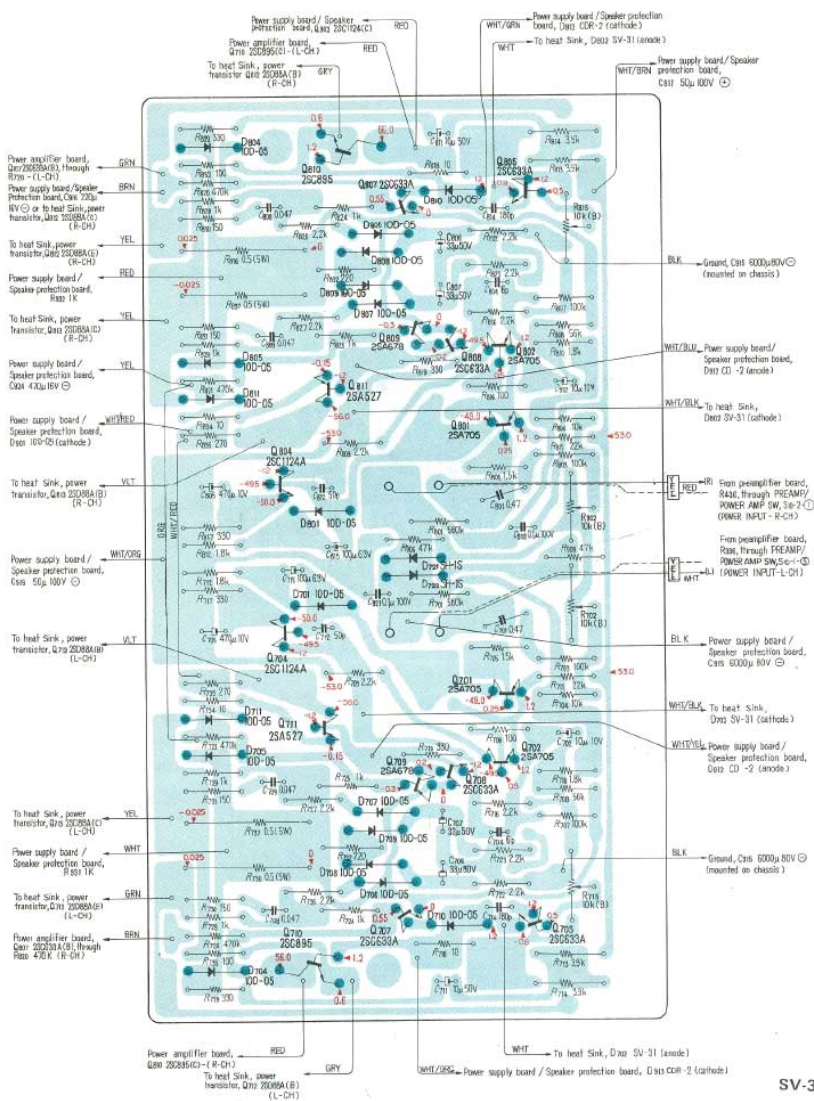

5-3. MOUNTING DIAGRAM — Power Amplifier Board —

— Component Side —

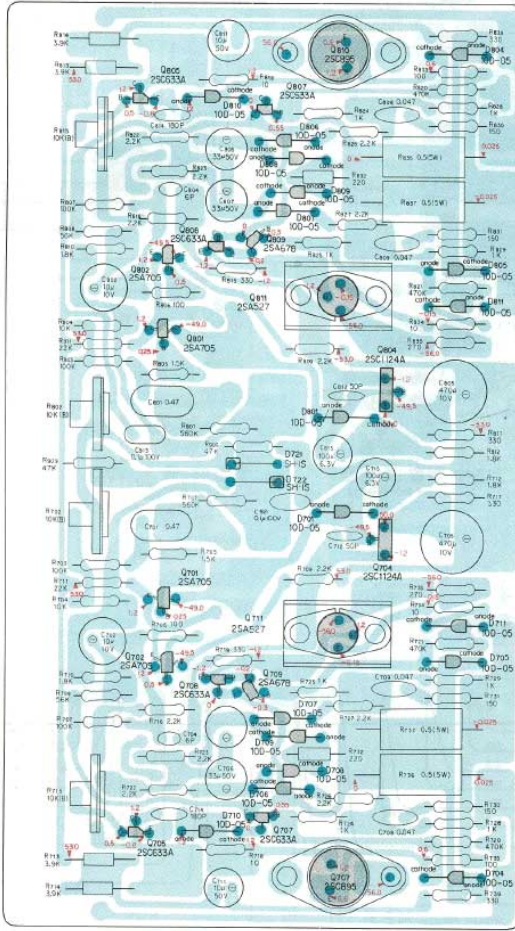

2SC895



2SA678



2SA705

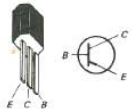

2SA527

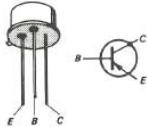

2SC1124A

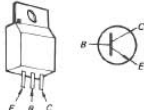

2SC633A

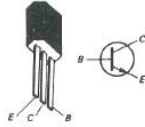

10D-05



SH-1S



54. MOUNTING DIAGRAM — Power Supply/Speaker Protection Board —
 — Component Side —

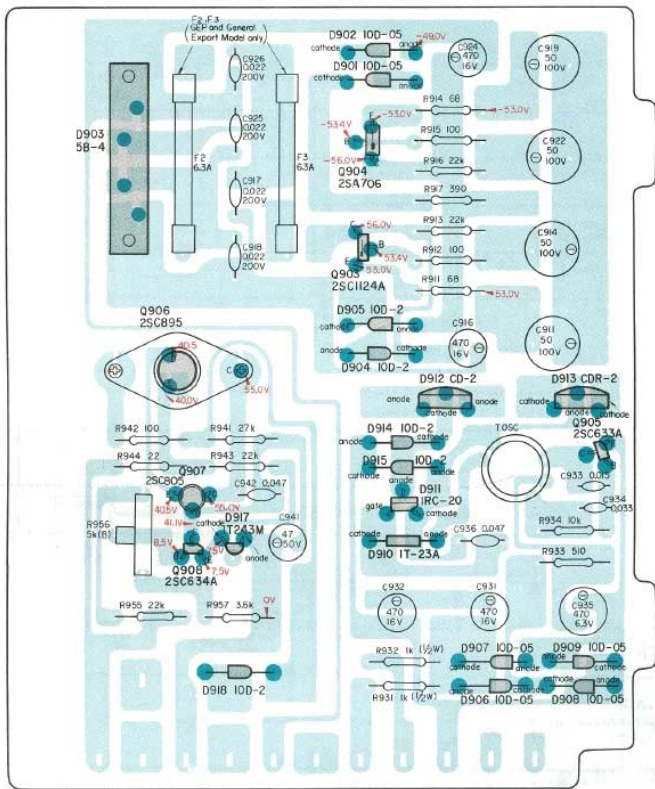

2SC1124

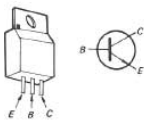

2SA706

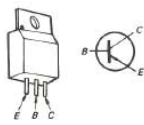

2SC895

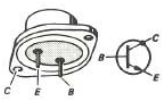

2SC633A
2SC634A

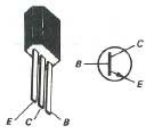

5B-4

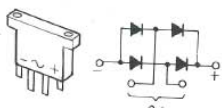

IRC-20

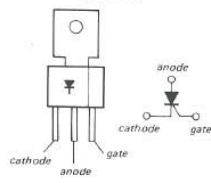

1T23A

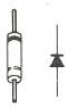

10D-05



1T243M

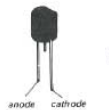

10D-2

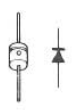

CDR-2



CD-2

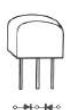

MEMO

A series of horizontal dotted lines for writing.

5.5. SCHEMATIC DIAGRAM — Preamplifier Section —

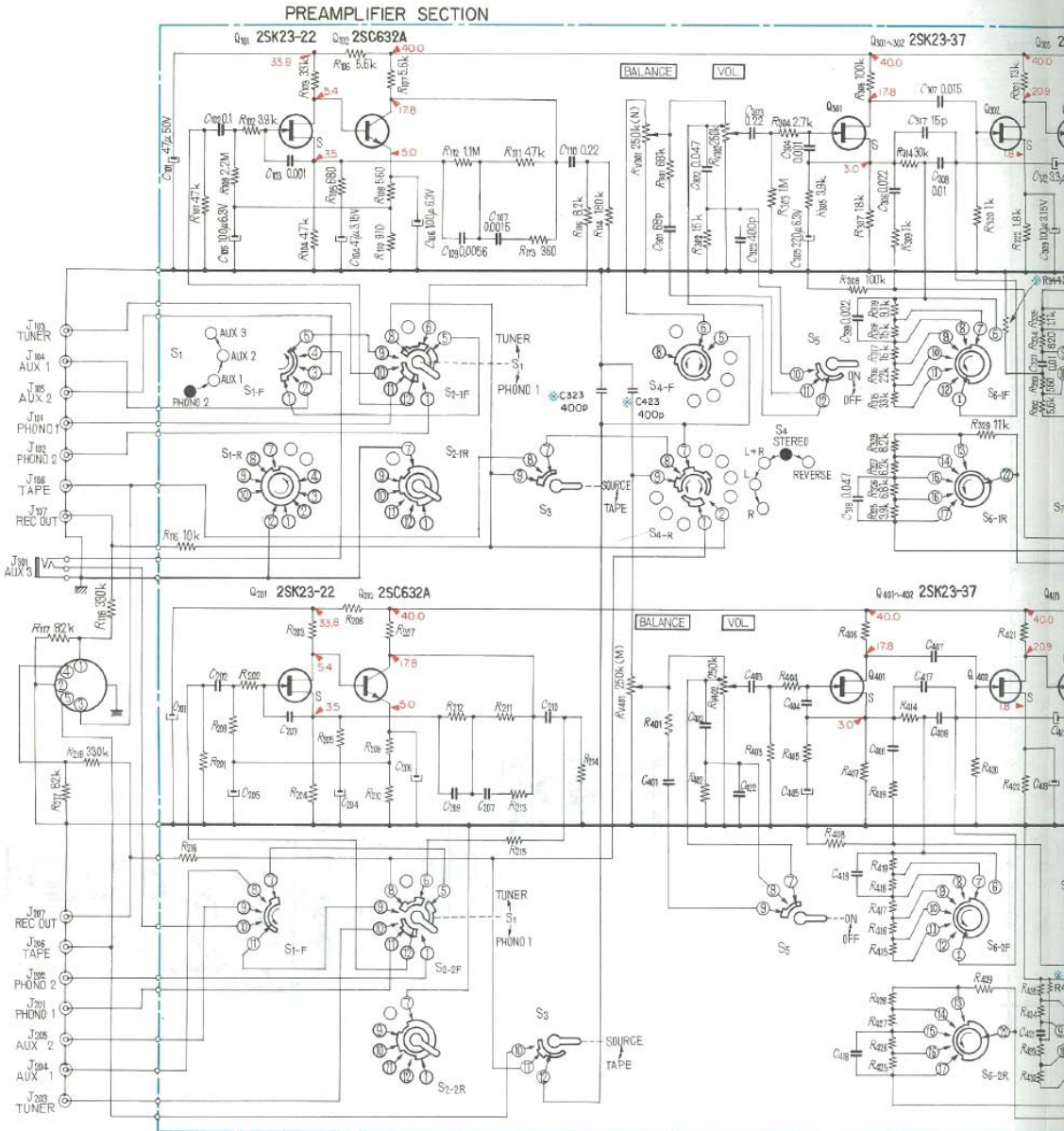

Ref. No.	Description	Position	Ref. No.	Description	Position	Ref. No.	Description
S1	FUNCTION (1) SW (PHONO 2 - AUX 1 - AUX 2 - AUX 3)	PHONO 2	S4	MODE SW (REVERSE - STEREO - L+R - LEFT - RIGHT)	STEREO	S8	HIGH FILTER SW
S2	FUNCTION (2) SW (PHONO 1 - FUNCTION (1) - TUNER)	PHONO 1	S5	LOUDNESS SW	ON	S9	LOW FILTER SW
S3	MONITOR SW (SOURCE - TAPE)	SOURCE	S6	BASS CONTROL SW	-10 dB	S10	PREAMP/POWER AMP SW (SEPARATE - NORMA
			S7	TREBLE CONTROL SW	-10 dB		

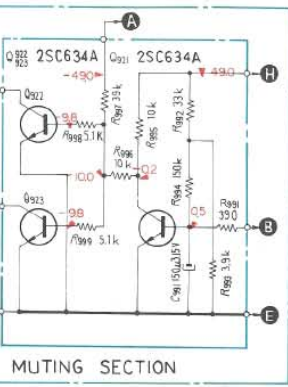
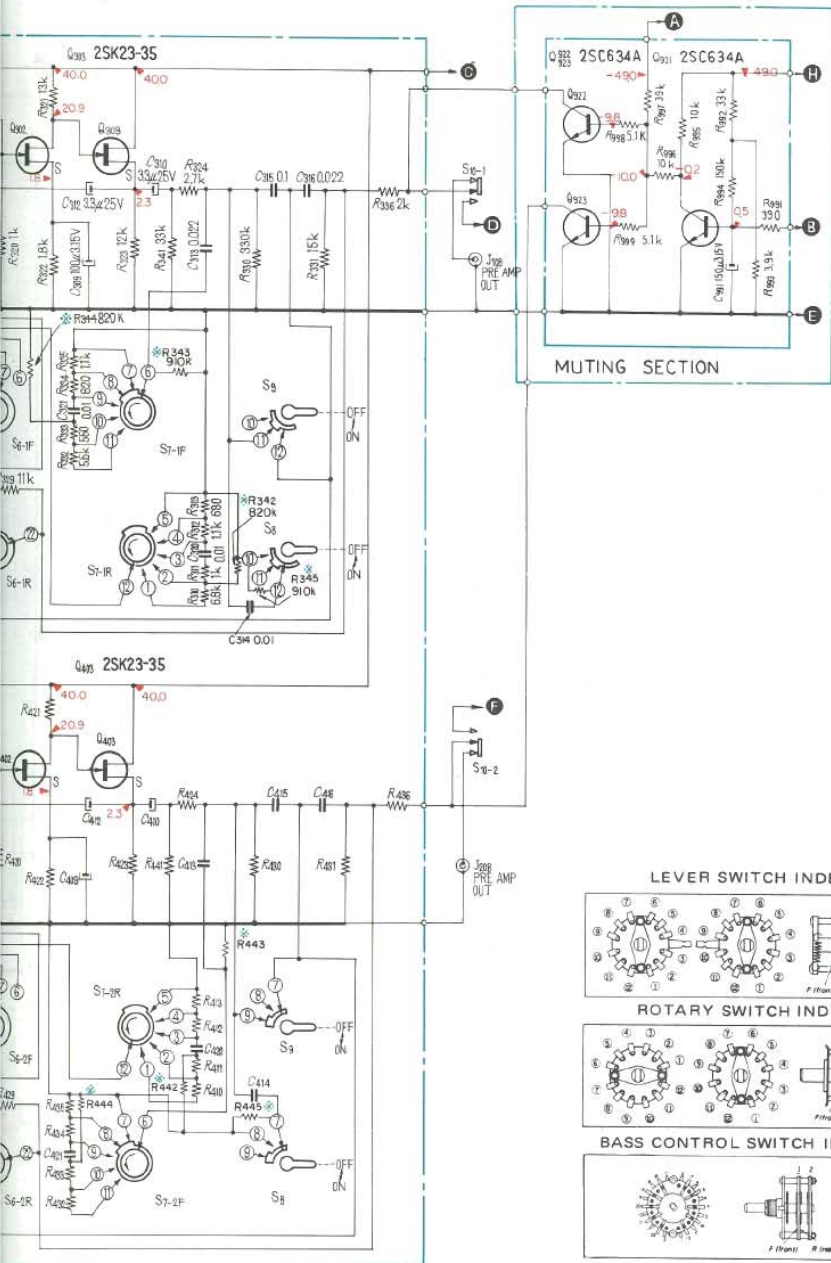

Position
 FILTER SW OFF
 TUNING SW OFF
 POWER SEPARATE
 SW (OFF - NORMAL)

Note:
 All resistance values are in ohms, k=1,000, M=1,000k.
 All capacitance values are in μ F except as indicated with p, which means μ F.
 All voltages represent an average value and should hold within $\pm 20\%$.
 All voltages are dc measured with a VOM which has an input impedance of 20k ohms/volt. No signal in.

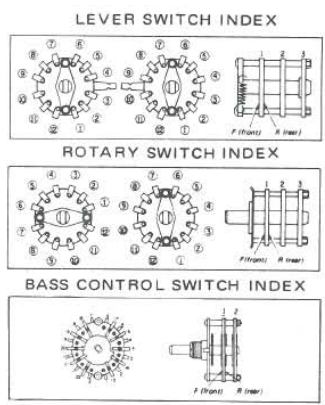

5-6. SCHEMATIC DIAGRAM — Power Amplifier Section —

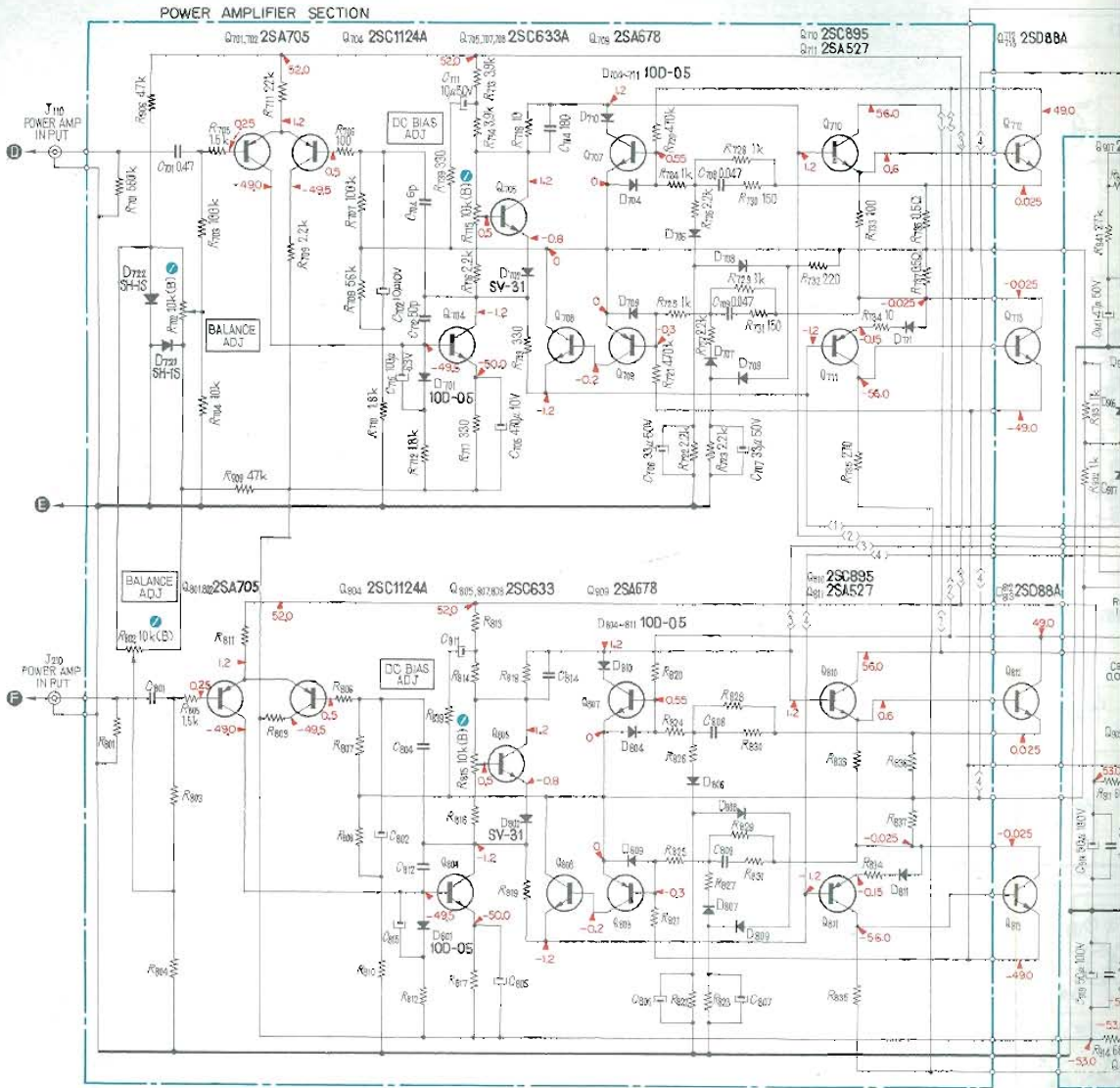

Ref. No.	Description	Position
S11	SPEAKER SW (REMOTE-OFF-MAIN-BOTH)	MAIN
S12	POWER SW (OFF-ON)	ON

SECTION 6
EXPLODED VIEW

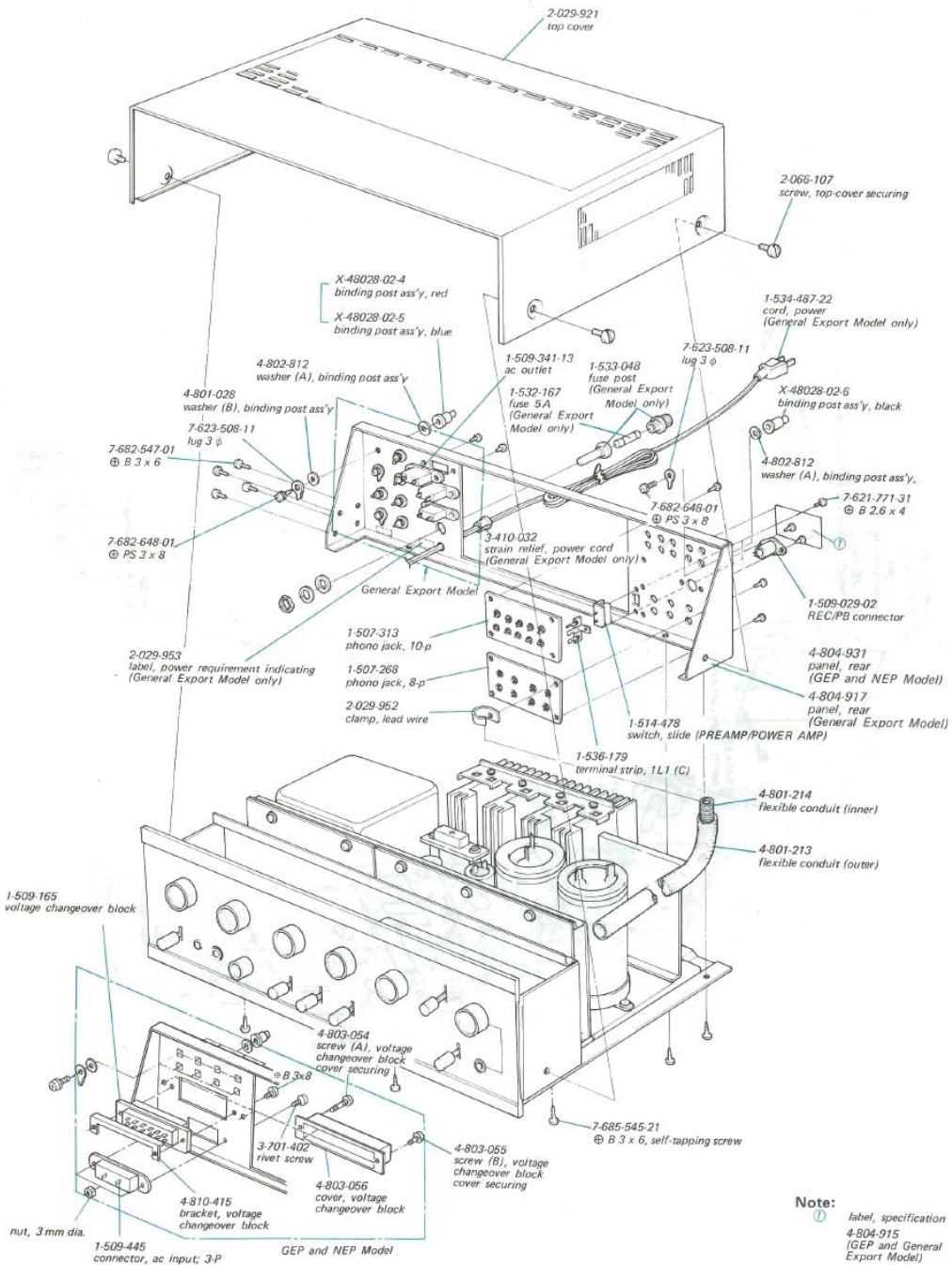

Note:

① label, specification

4-804-915 (GEP and General Export Model)

4-804-941 (NEP Model)

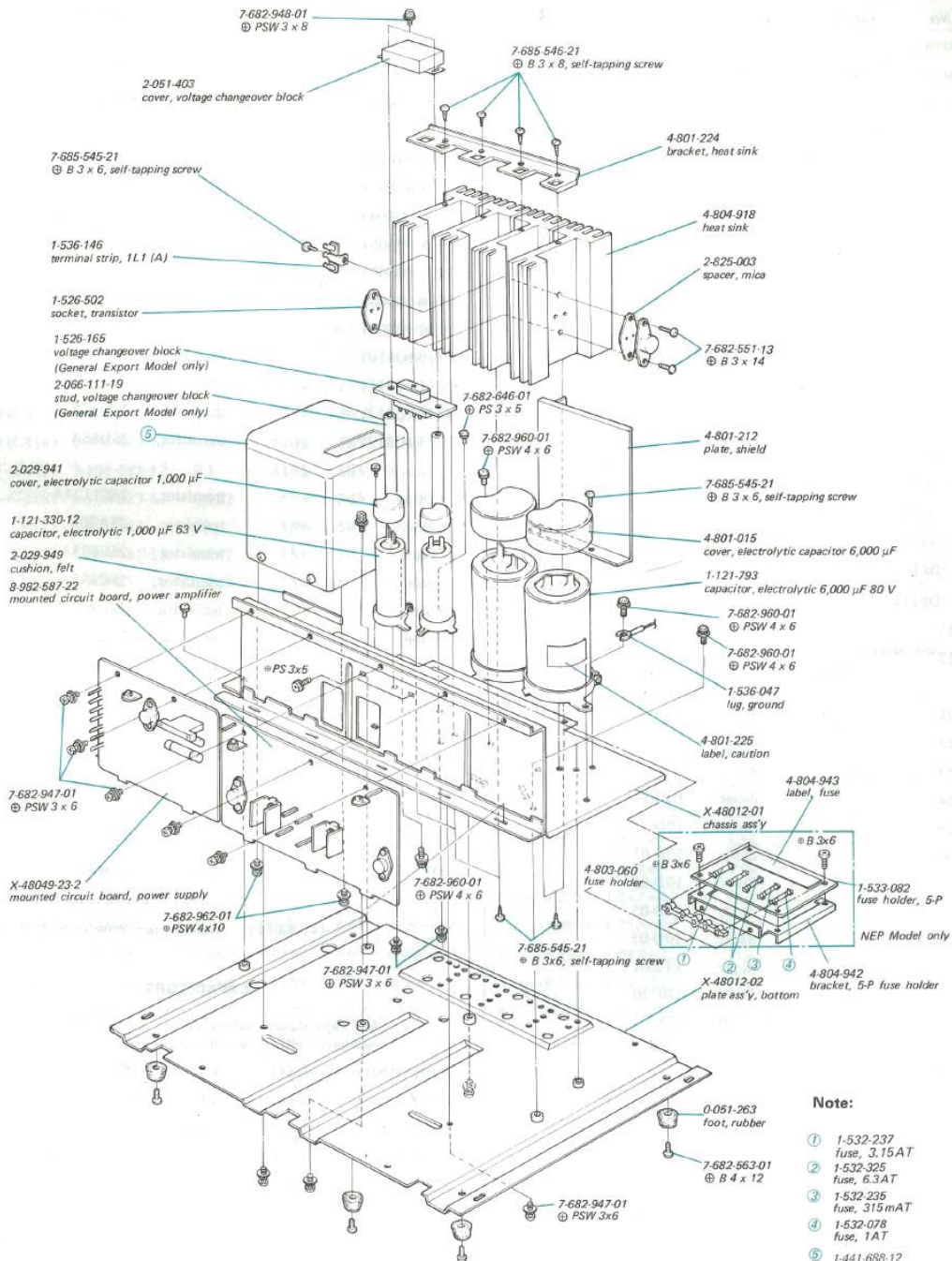

Note:

- ① 1-532-237
fuse, 3.15AT
- ② 1-532-325
fuse, 6.3AT
- ③ 1-532-235
fuse, 315mA
- ④ 1-532-078
fuse, 1AT
- ⑤ 1-441-688-12
transformer, power
(GEP and General Export Model)
- 1-441-830-11
transformer, power
(NEP Model)

SECTION 7

ELECTRICAL PARTS LIST

<u>Ref. No.</u>	<u>Part No.</u>	<u>Description</u>	<u>Ref. No.</u>	<u>Part No.</u>	<u>Description</u>
MOUNTED CIRCUIT BOARDS					
X-48049-21-3		preamplifier circuit board	Q302 (Q402)		FET, 2SK23-37
8-982-587-22		power amplifier circuit board	Q303 (Q403)		FET, 2SK23-35
X-48049-23-2		power supply circuit board	Q701 (Q801)		transistor, 2SA705
8-982-587-88		muting circuit board	Q702 (Q802)		transistor, 2SA705
SEMICONDUCTORS			Q704 (Q804)		transistor, 2SC1124A
D701 (D801)	diode,	10D-05	Q705 (Q805)		transistor, 2SC633A
D702 (D802)	varistor,	SV-31	Q707 (Q807)		transistor, 2SC633A
D704 (D804)	diode,	10D-05	Q708 (Q808)		transistor, 2SC633A
D705 (D805)	diode,	10D-05	Q709 (Q809)		transistor, 2SA678
D706 (D806)	diode,	10D-05	Q710 (Q810)		transistor, 2SC895
D707 (D807)	diode,	10D-05	Q711 (Q811)		transistor, 2SA527
D708 (D808)	diode,	10D-05	Q712 (Q812)		transistor, 2SD88A
D709 (D809)	diode,	10D-05	Q713 (Q813)		transistor, 2SD88A
D710 (D810)	diode,	10D-05	Q903		transistor, 2SC1124A
D711 (D811)	diode,	10D-2	Q904		transistor, 2SA706
D721	diode,	SH-1S	Q905		transistor, 2SC633A
D722	diode,	SH-1S	Q906		transistor, 2SC895
D901	diode,	10D-05	Q907		transistor, 2SC805
D902	diode,	10D-05	Q908		transistor, 2SC634A
D903	diode,	5B4	Q921		transistor, 2SC634A
D904	diode,	10D-2	Q922		transistor, 2SC634A
D905	diode,	10D-2	Q923		transistor, 2SC634A
D906	diode,	10D-05	TRANSFORMERS		
D907	diode,	10D-05	T osc	1-433-132-27	transformer, osc.
D908	diode,	10D-05	T	1-441-688-12	transformer, power (GEP and General Export Model)
D909	diode,	10D-05		1-441-830-11	transformer, power (NEP Model)
D910	diode,	1T23A	CAPACITORS		
D911	SCR,	1RC20	All capacitance values are in μF except as indicated with p, which means $\mu\mu\text{F}$.		
D912	diode,	CD-2	C101 (C201)	1-121-411	47 $\pm 10\%$ 50V electrolytic
D913	diode,	CDR-2	C102 (C202)	1-105-685-12	0.1 $\pm 10\%$ 50V mylar
D914	diode,	10D-2	C103 (C203)	1-105-661-12	0.001 $\pm 10\%$ 50V mylar
D915	diode,	10D-2	C104 (C204)	1-121-406	47 $\pm 10\%$ 3.15V electrolytic
D917	diode,	1T243M	C105 (C205)	1-121-413	100 $\pm 10\%$ 6.3V electrolytic
D918	diode,	10D-2	C106 (C206)	1-121-413	100 $\pm 10\%$ 6.3V electrolytic
Q101 (Q201)	FET,	2SK23-22	C107 (C207)	1-106-005-12	0.0015 $\pm 5\%$ 50V mylar
Q102 (Q202)	transistor,	2SC632A	C108 (C208)		- discarded -
Q301 (Q401)	FET,	2SK23-37	C109 (C209)	1-106-019-12	0.0056 $\pm 5\%$ 50V mylar

<u>Ref. No.</u>	<u>Part No.</u>	<u>Description</u>			<u>Ref. No.</u>	<u>Part No.</u>	<u>Description</u>		
C110 (C210)	1-105-689-12	0.22	±10%	50V mylar	C917	1-105-917-12	0.022	±20%	200V mylar
C301 (C401)	1-101-888	68 p	±5%	50V ceramic	C918	1-105-917-12	0.022	±20%	200V mylar
C302 (C402)	1-106-041-12	0.047	±5%	50V mylar	C919	1-121-559	50	±100%	100V electrolytic
C303 (C403)	1-105-689-12	0.22	±10%	50V mylar	C922	1-121-559	50	±100%	100V electrolytic
C304 (C404)	1-105-661-12	0.001	±10%	50V mylar	C923	1-121-793	6,000	±100%	80V electrolytic
C305 (C405)	1-121-420	220	±100%	10V electrolytic	C924	1-121-426	470	±100%	16V electrolytic
C306 (C406)	1-106-033-12	0.022	±5%	50V mylar	C925	1-105-917-12	0.022	±20%	200V mylar
C307 (C407)	1-105-675-12	0.015	±10%	50V mylar	C926	1-105-917-12	0.022	±20%	200V mylar
C308 (C408)	1-106-025-12	0.01	±5%	50V mylar	C931	1-121-426	470	±100%	16V electrolytic
C309 (C409)	1-121-413	100	±100%	6.3V electrolytic	C932	1-121-426	470	±100%	16V electrolytic
C310 (C410)	1-121-392	3.3	±150%	25V electrolytic	C933	1-105-675-12	0.015	±10%	50V mylar
C312 (C412)	1-121-392	3.3	±150%	25V electrolytic	C934	1-105-679-12	0.033	±10%	50V mylar
C313 (C413)	1-106-033-12	0.022	±5%	50V mylar	C935	1-121-425	470	±100%	10V electrolytic
C314 (C414)	1-105-673-12	0.01	±10%	50V mylar	C936	1-105-681-12	0.047	±10%	50V mylar
C315 (C415)	1-105-685-12	0.1	±10%	50V mylar	C941	1-121-411	47	±100%	50V electrolytic
C316 (C416)	1-106-033-12	0.022	±5%	50V mylar	C942	1-105-721-12	0.047	±10%	100V mylar
C317 (C417)	1-101-861	15 p	±5%	50V ceramic	C943	1-121-330	1,000	±100%	63V electrolytic
C318 (C418)	1-106-041-12	0.047	±5%	50V mylar	C944	1-121-330	1,000	±100%	63V electrolytic
C319 (C419)	1-106-033-12	0.022	±5%	50V mylar	C991	1-121-741	150	±20%	3.15V electrolytic
C320 (C420)	1-106-025-12	0.01	±5%	50V mylar					
C321 (C421)	1-106-025-12	0.01	±5%	50V mylar					
C322 (C422)	1-101-099	400 p	±20%	50V ceramic					
C323 (C423)	1-101-099	400 p	±20%	50V ceramic					
C701 (C801)	1-105-693-12	0.47	±10%	50V mylar					
C702 (C802)	1-121-469	10	±100%	10V electrolytic					
C704 (C804)	1-102-943	6 p	±0.5 pF	50V ceramic					
C705 (C805)	1-121-425	470	±100%	10V electrolytic					
C706 (C806)	1-121-405	33	±100%	50V electrolytic					
C707 (C807)	1-121-405	33	±100%	50V electrolytic					
C708 (C808)	1-105-681-12	0.047	±10%	50V mylar					
C709 (C809)	1-105-681-12	0.047	±10%	50V mylar					
C710 (C810)	1-105-679-12	0.033	±10%	50V mylar					
C711 (C811)	1-121-738	10	±100%	50V electrolytic					
C712 (C812)	1-107-002	50 p	±10%	500V silvered mica					
C714 (C814)	1-107-091	180 p	±5%	50V silvered mica					
C715 (C815)	1-121-413	100	±100%	6.3V electrolytic					
C911	1-121-559	50	±100%	100V electrolytic					
C913 (C921)	1-105-725-12	0.1	±10%	100V mylar					
C914	1-121-559	50	±100%	100V electrolytic					
C915	1-121-793	6,000	±100%	80V electrolytic					
C916	1-121-426	470	±100%	16V electrolytic					
RESISTORS									
All resistance values are in ohms, ±5%, ¼ watts and carbon type unless otherwise indicated.									
R101 (R201)	1-244-713	47k							
R102 (R202)	1-242-687	3.9k							
R103 (R203)	1-242-709	33k							
R104 (R204)	1-242-689	4.7k							
R105 (R205)	1-242-669	680							
R106 (R206)	1-242-691	5.6k							
R107 (R207)	1-242-691	5.6k							
R108 (R208)	1-242-667	560							
R109 (R209)	1-210-051	2.2M							
R110 (R210)	1-242-672	910							
R111 (R211)	1-242-713	47k							
R112 (R212)	1-210-124	1.1M							
R113 (R213)	1-242-662	360							
R114 (R214)	1-242-727	180k							
R115 (R215)	1-242-695	8.2k							
R116 (R216)	1-244-697	10k							
R117 (R217)	1-244-719	82k							
R118 (R218)	1-244-733	330k							
R301 (R401)	1-242-717	68k							
R302 (R402)	1-242-701	15k							
R303 (R403)	1-242-745	1M							

SECTION 7

ELECTRICAL

<u>Ref. No.</u>	<u>Part No.</u>	<u>Description</u>	<u>Ref. No.</u>	<u>Part No.</u>	<u>Description</u>	
R304 (R404)	1-242-683	2.7k	R704 (R804)	1-244-697	10k	
R305 (R405)	1-242-687	3.9k	R705 (R805)	1-244-677	1.5k	
R306 (R406)	1-242-721	100k	R706 (R806)	1-244-649	100	
R307 (R407)	1-242-703	18k	R707 (R807)	1-244-721	100k	
R308 (R408)	1-242-721	100k	R708 (R808)	1-244-715	56k	
R309 (R409)	1-242-673	1k	R709 (R809)	1-244-681	2.2k	
R310 (R410)	1-244-493	6.8k	1/8 W	R710 (R810)	1-244-679	1.8k
R311 (R411)	1-244-473	1k	1/8 W	R711 (R811)	1-244-705	22k
R312 (R412)	1-244-474	1.1k	1/8 W	R712 (R812)	1-244-679	1.8k
R313 (R413)	1-244-469	680	1/8 W	R713 (R813)	1-202-587	3.9k ±10% 1/2 W composition
R314 (R414)	1-242-708	30k		R714 (R814)	1-202-587	3.9k ±10% 1/2 W composition
R315 (R415)	1-244-509	33k	1/8 W	R715 (R815)	1-221-967	10k (B), semi-fixed
R316 (R416)	1-244-505	22k	1/8 W	R716 (R816)	1-244-681	2.2k
R317 (R417)	1-244-502	16k	1/8 W	R717 (R817)	1-244-661	330
R318 (R418)	1-244-501	15k	1/8 W	R718 (R818)	1-244-625	10
R319 (R419)	1-244-496	9.1k	1/8 W	R719 (R819)	1-244-661	330
R320 (R420)	1-242-745	1M		R720 (R820)	1-244-737	470k
R321 (R421)	1-242-700	13k		R721 (R821)	1-244-737	470k
R322 (R422)	1-242-679	1.8k		R722 (R822)	1-244-681	2.2k
R323 (R423)	1-242-699	12k		R723 (R823)	1-244-681	2.2k
R324 (R424)	1-242-683	2.7k		R724 (R824)	1-244-673	1k
R325 (R425)	1-244-487	3.9k	1/8 W	R725 (R825)	1-244-673	1k
R326 (R426)	1-244-493	6.8k	1/8 W	R726 (R826)	1-244-681	2.2k
R327 (R427)	1-244-492	6.2k	1/8 W	R727 (R827)	1-244-681	2.2k
R328 (R428)	1-244-495	8.2k	1/8 W	R728 (R828)	1-244-673	1k
R329 (R429)	1-244-498	11k	1/8 W	R729 (R829)	1-244-673	1k
R330 (R430)	1-242-733	330k		R730 (R830)	1-244-653	150
R331 (R431)	1-242-701	15k		R731 (R831)	1-244-653	150
R332 (R432)	1-244-491	5.6k	1/8 W	R732 (R832)	1-202-557	220 ±10% 1/2 W composition
R333 (R433)	1-244-467	560	1/8 W	R733 (R833)	1-244-649	100
R334 (R434)	1-244-471	820	1/8 W	R734 (R834)	1-244-625	10
R335 (R436)	1-244-474	1.1k	1/8 W	R735 (R835)	1-244-659	270
R336 (R436)	1-242-680	2k		R736 (R836)	1-205-803	0.5 ±10% 5W wire-wound
R341 (R441)	1-244-709	33k		R737 (R837)	1-205-803	0.5 ±10% 5W wire-wound
R342 (R442)	1-244-543	820k		R738 (R838)	1-202-525	10 ±10% 1/2 W composition
R343 (R443)	1-242-744	910k		R739 (R839)	1-244-661	330
R344 (R444)	1-244-543	820k		R906 (R909)	1-244-713	47k
R345 (R445)	1-242-744	910k		R911	1-244-645	68
R508 (R608)	1-202-565	10	±10% 1/2 W composition	R912	1-244-649	100
R509 (R609)	1-207-167	500	±10% 1.5W wire-wound	R913	1-244-705	22k
R701 (R801)	1-244-739	560k		R914	1-244-645	68
R702 (R802)	1-221-967	10k (B), semi-fixed		R915	1-244-649	100
R703 (R803)	1-244-721	100k		R916	1-244-705	22k
				R917	1-244-663	390

<u>Ref. No.</u>	<u>Part No.</u>	<u>Description</u>	<u>Ref. No.</u>	<u>Part No.</u>	<u>Description</u>
R931	1-202-573	1k	S12	1-514-369-23	switch, lever/rotary (POWER) (GEP and General Export Model)
R932	1-202-573	1k		1-514-965	switch, lever/rotary (POWER) (NEP Model)
R933	1-244-666	510	MISCELLANEOUS		
R934	1-244-697	10k	1-507-190-12	jack, HEADPHONE	
R941	1-244-707	27k	1-507-260	jack, AUX-3	
R942	1-202-549	100 ±10% ½ W composition	1-507-268	phono jack, 8-P	
R943	1-244-705	22k	1-507-313	phono jack, 10-P	
R944	1-202-533	22 ±10% ½ W composition	1-509-029	REC/PB connector	
R955	1-244-705	22k	1-509-341-13	ac outlet (General Export Model only)	
R956	1-221-996	5k (B), semi-fixed	1-509-445	ac input connector, 3-P (GEP and NEP Model only)	
R957	1-244-686	3.6k	1-517-021	socket, pilot lamp	
R991	1-242-663	390	1-518-052	lamp, pilot	
R992	1-242-709	33k	1-526-165	voltage changeover block	
R993	1-242-687	3.9k	1-526-502	socket, transistor	
R994	1-242-725	150k	1-532-325	fuse, 6.3AT (F2, F3) (NEP Model only)	
R995	1-202-597	10k ±10% ½ W composition	1-532-256	fuse, 6.3A (F2, F3) (GEP and General Export Model only)	
R996	1-242-697	10k	1-532-237	fuse, 3.15AT (F1) (NEP Model only)	
R997	1-242-711	39k	1-532-167	fuse, 5A (F1) (General Export Model only)	
R998	1-242-690	5.1k	1-532-255	fuse, 5A (F1) (GEP Model only)	
R999	1-242-690	5.1k	1-532-078	fuse, 1AT (F4) (NEP Model only)	
RV301 } (RV401) }	1-221-844	250k, variable (BALANCE control)	1-532-235	fuse, 315 mA (F5) (NEP Model only)	
RV302 } (RV402) }	1-222-445	250k, variable (VOLUME control)	1-533-082	fuse holder, 5-P (NEP Model only)	
SWITCHES			1-533-048	fuse post (General Export Model only)	
S1	1-514-650	switch, rotary (FUNCTION 1)	1-536-047	pin, connecting	
S2	1-514-651	switch, lever/rotary (FUNCTION 2)	1-536-146	terminal strip, 1L1 (A)	
S3	1-513-338	switch, lever/rotary (MONITOR)	1-536-179	terminal strip, 1L1 (C)	
S4	1-514-795	switch, rotary (MODE)	1-536-189	terminal strip, 1L1 (GEP Model only)	
S5	1-513-338	switch, lever/rotary (LOUDNESS)	CP	encapsulated component, 120 Ω + 0.033 μF (General Export Model only)	
S6	1-514-648	switch, rotary (TONE control, BASS)	1-534-487-22	cord, power (General Export Model only)	
S7	1-514-652	switch rotary (TONE control, TREBLE)	1-506-108	pin, connecting	
S8	1-513-338	switch, lever/rotary (HIGH FILTER)			
S9	1-513-338	switch, lever/rotary (LOW FILTER)			
S10	1-514-478	switch, slide (PRE AMP/POWER AMP)			
S11	1-514-522	switch, rotary (SPEAKER)			

